

4

3

2

1

D

D

C

C

B

B

B

B

A

A

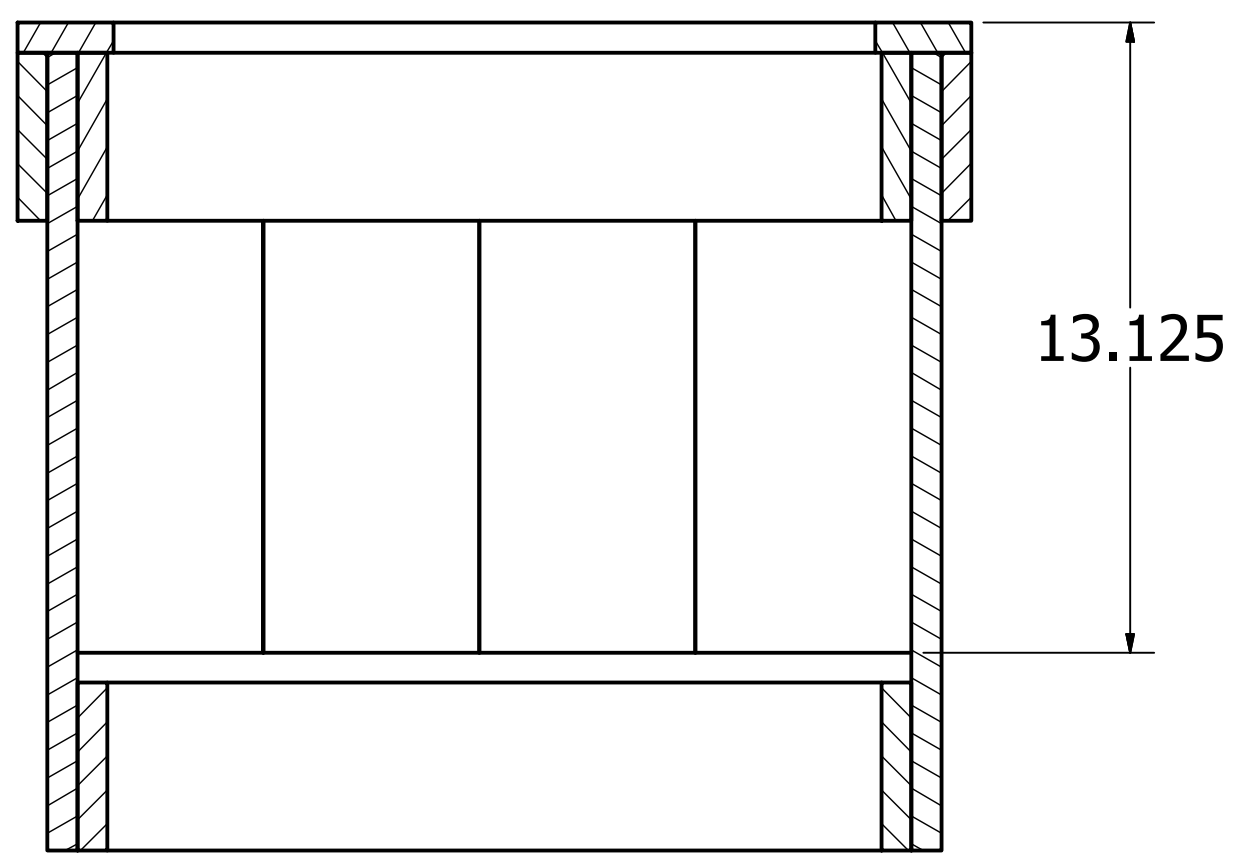
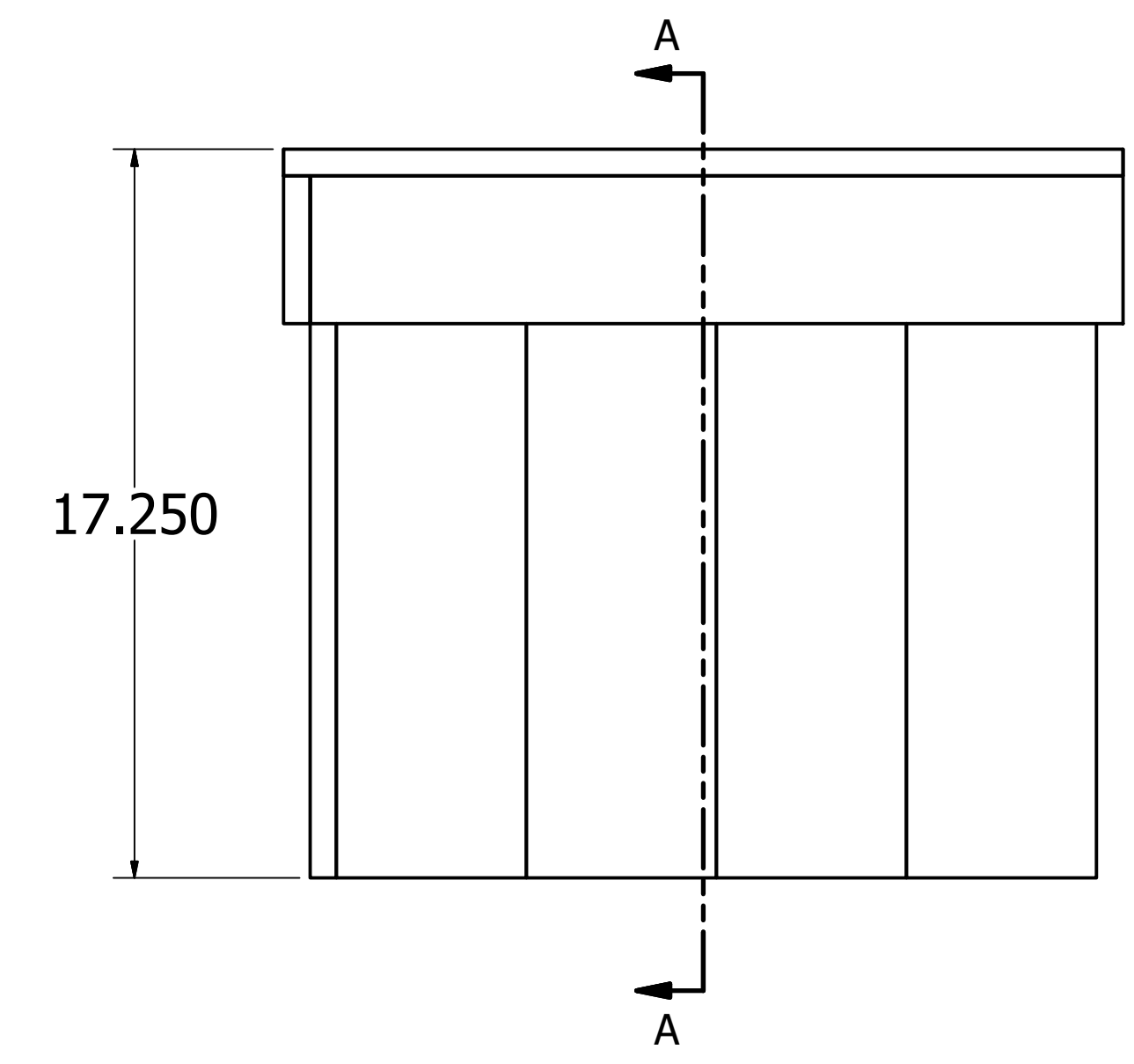
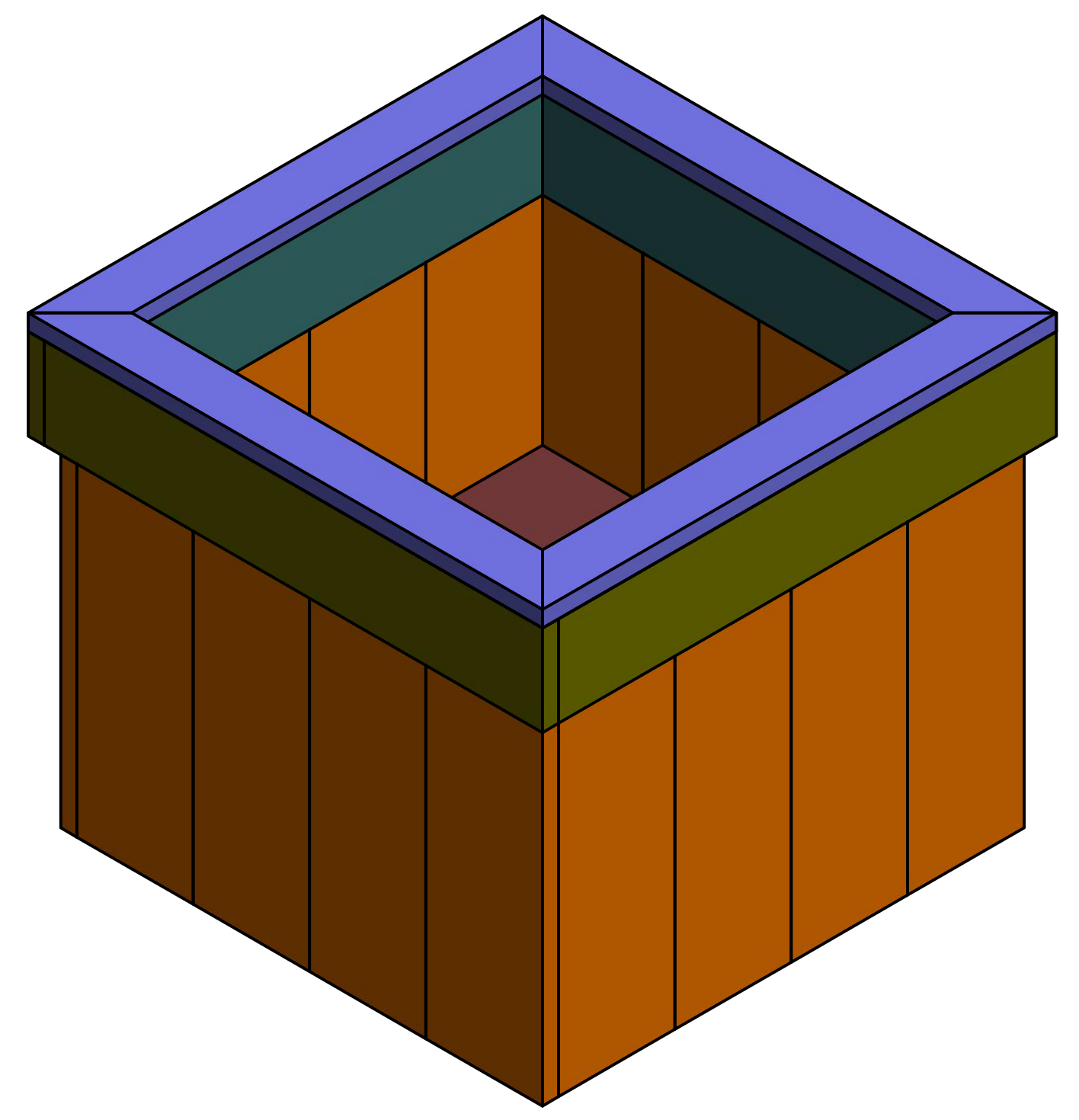
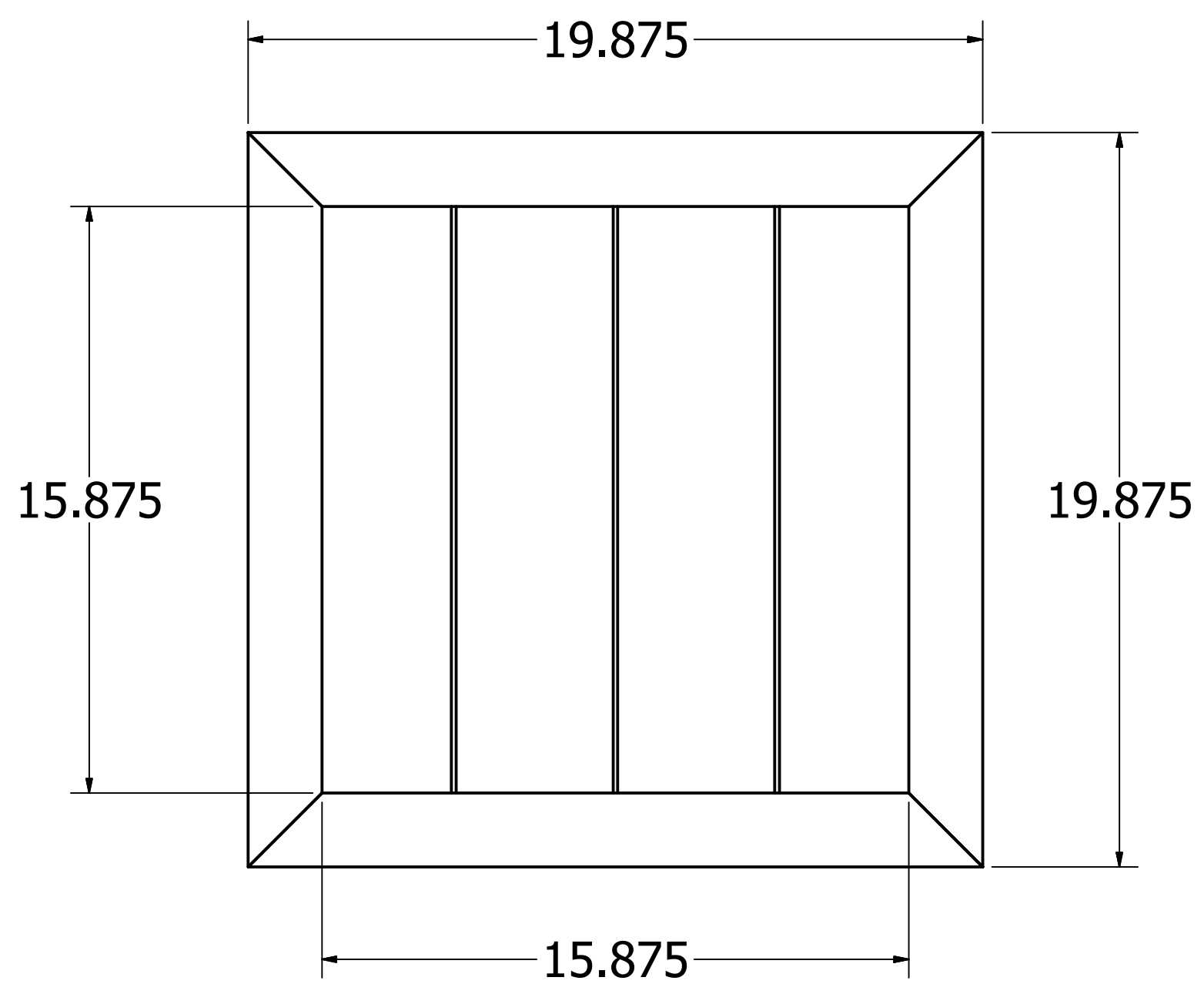

SECTION A-A
SCALE 1 / 4

DRAWN	MI	1/15/2014		
CHECKED			TITLE	
QA				
MFG				
APPROVED				
		SIZE	DWG NO	REV
		C	planter	
		SCALE	SHEET 1 OF 4	

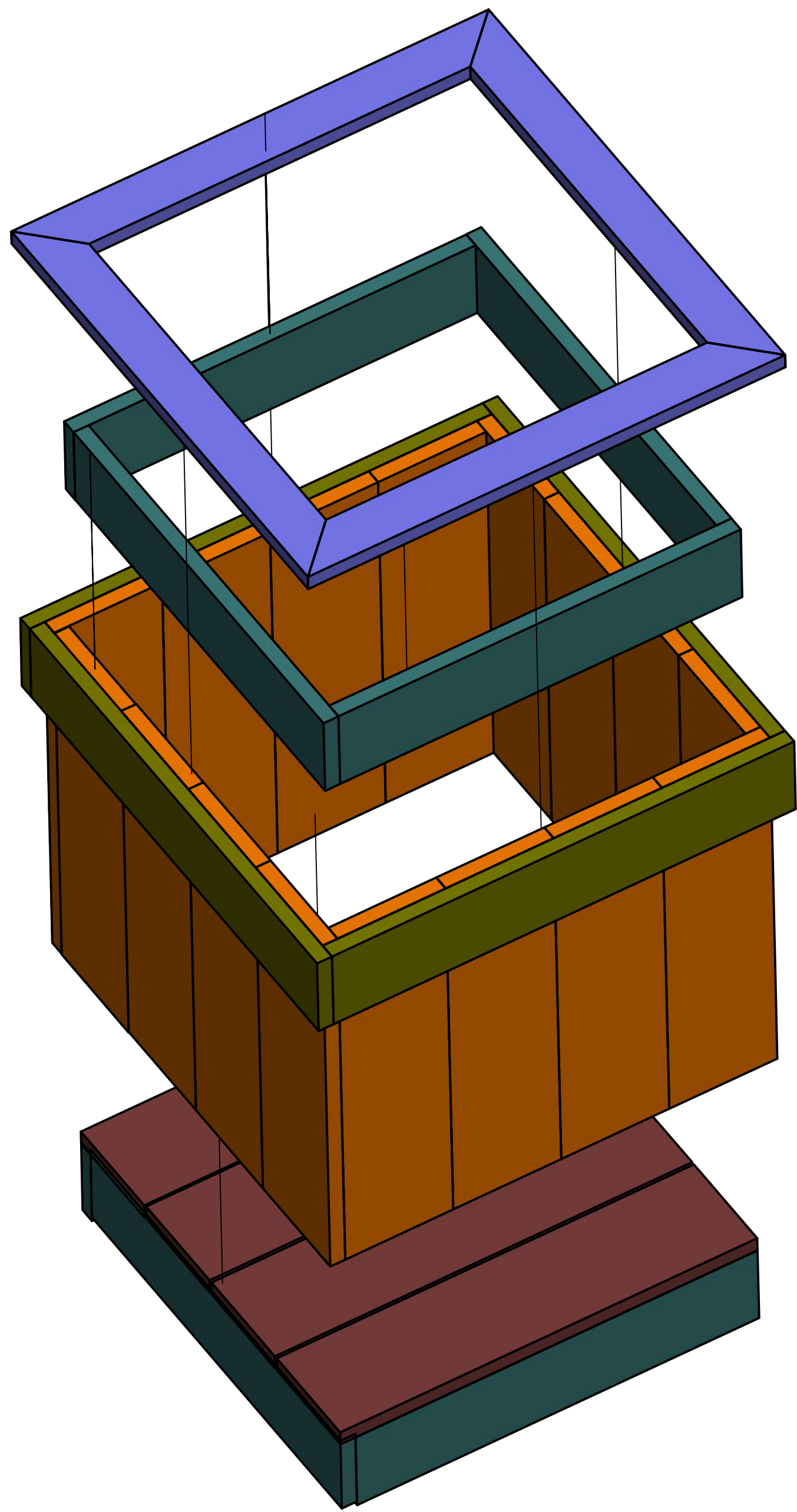

PARTS LIST			
ITEM	QTY	PART NAME	DESCRIPTION
1	8	Platform/Frame Side	16 3/4" x 3 1/2" x 5/8"
2	4	Platform Slat	17 3/8" x 4 1/4" x 5/8"
3	16	Side	16 5/8" x 4 1/2" x 5/8"
4	4	Outer Trim	19 1/4" x 3 1/2" x 5/8"
5	4	Top Trim	19 7/8" x 2" x 5/8"

DRAWN	MI	1/15/2014		
CHECKED			TITLE	
QA				
MFG				
APPROVED				
		SIZE	DWG NO	REV
		C	planter	
		SCALE	SHEET 2 OF 4	

4

3

2

1

D

D

C

C

B

B

A

A

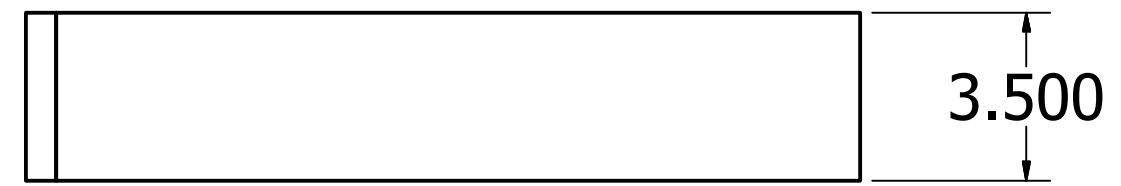
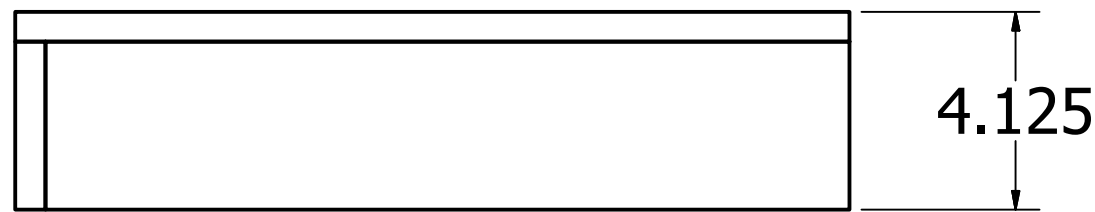
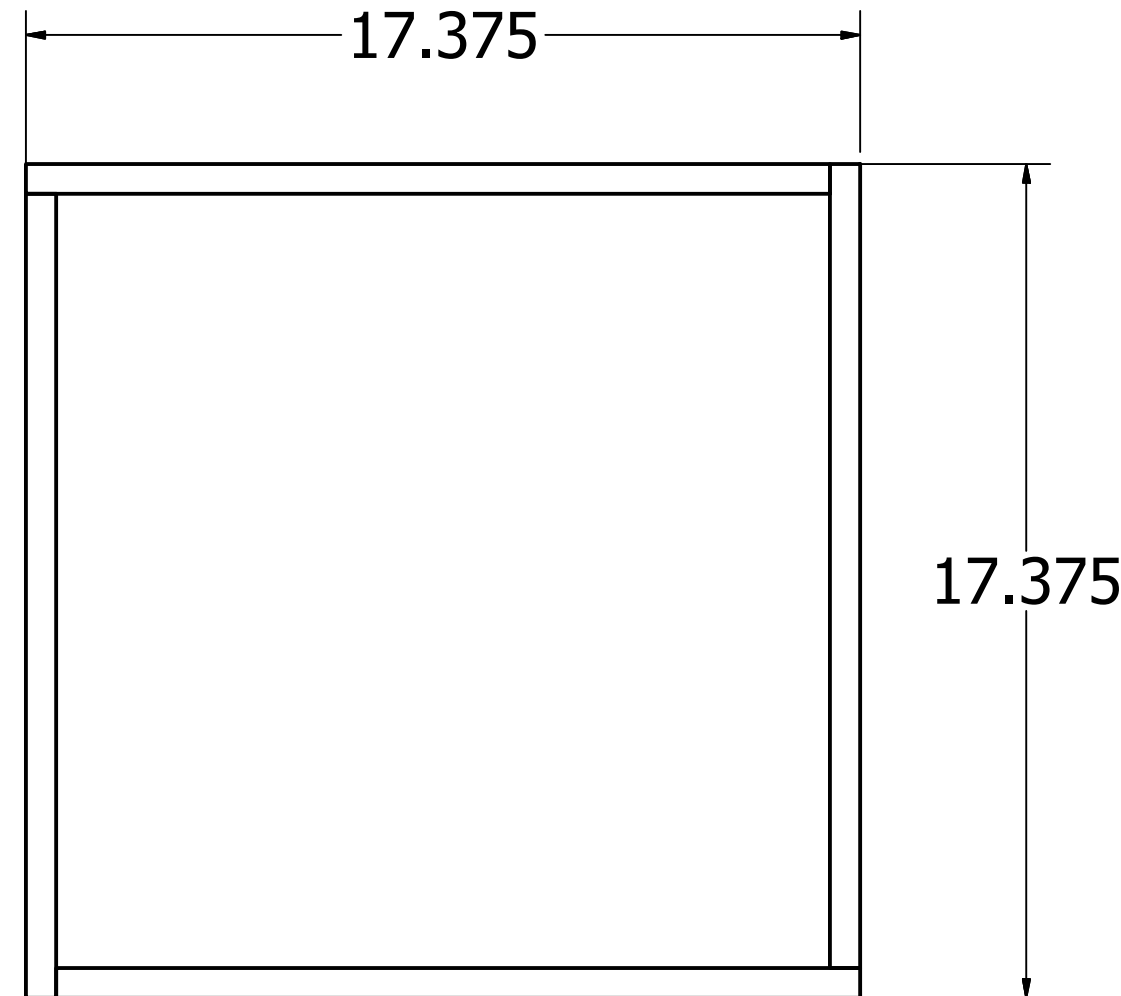
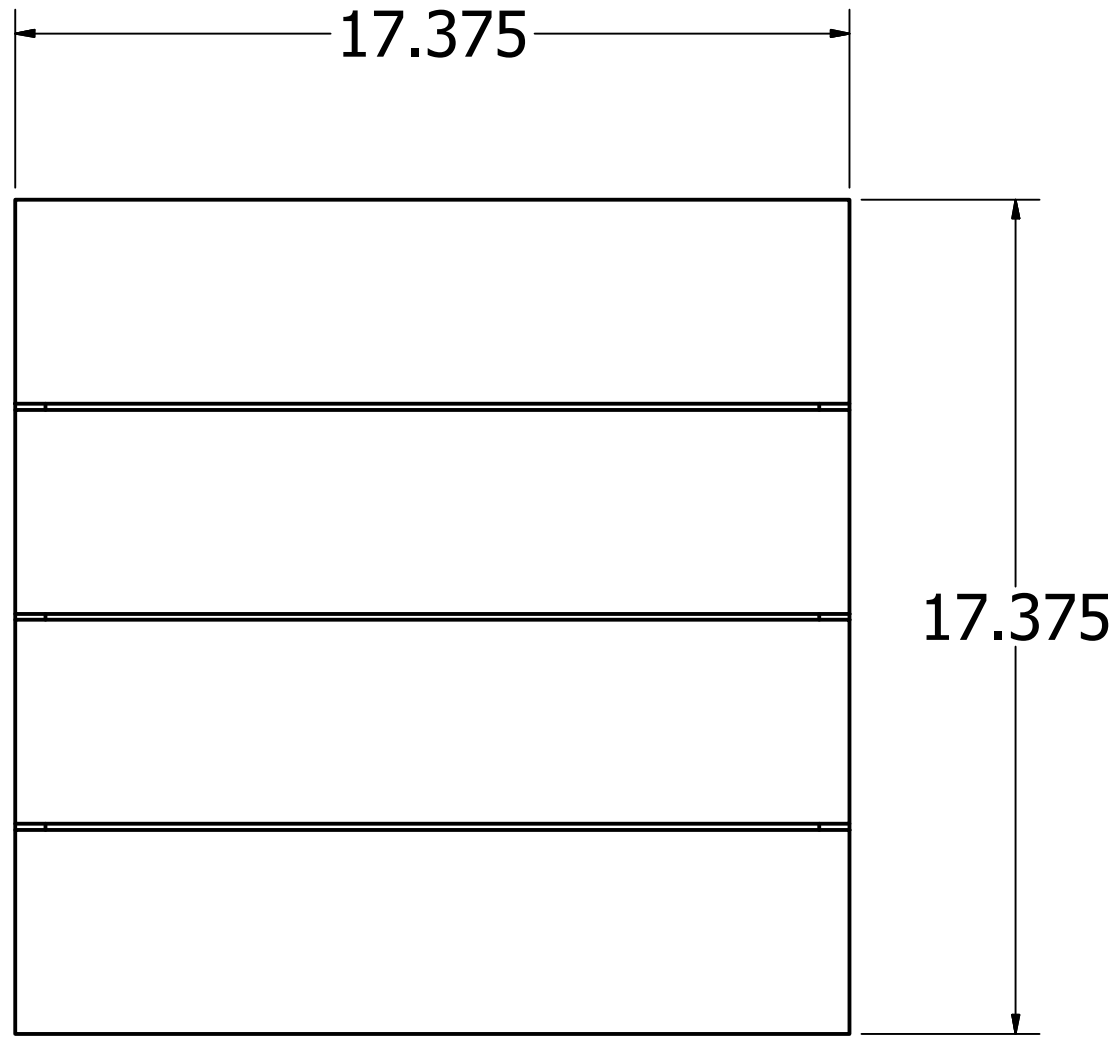
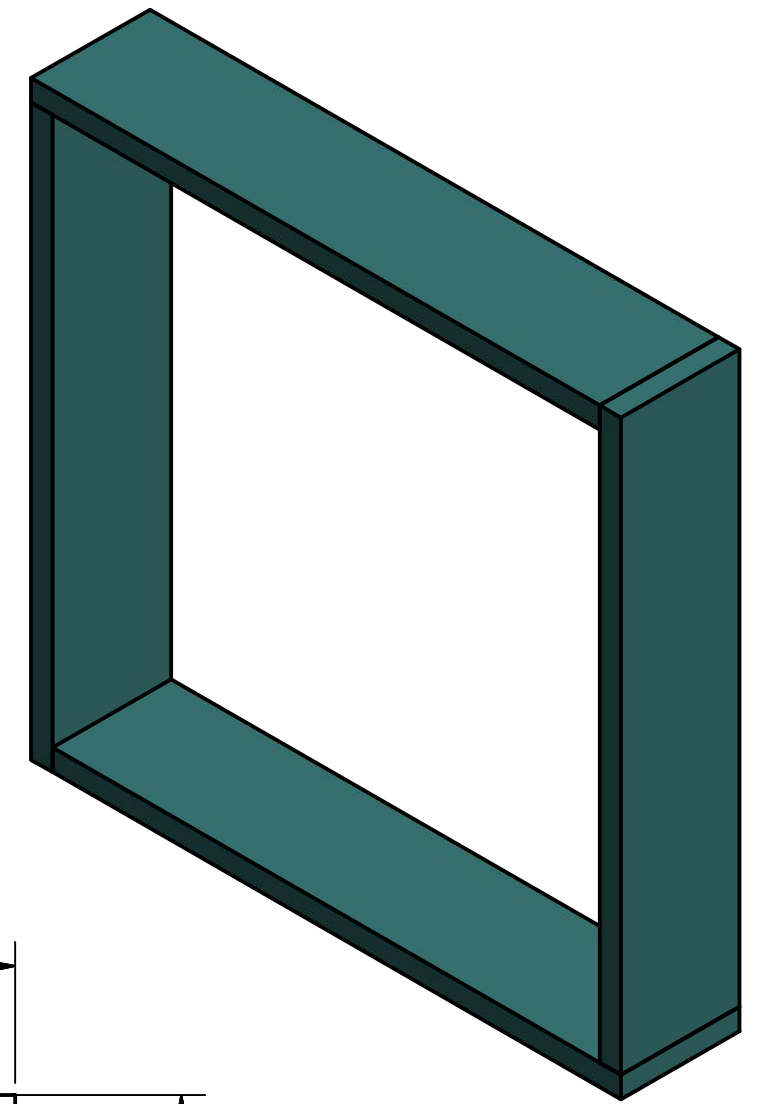
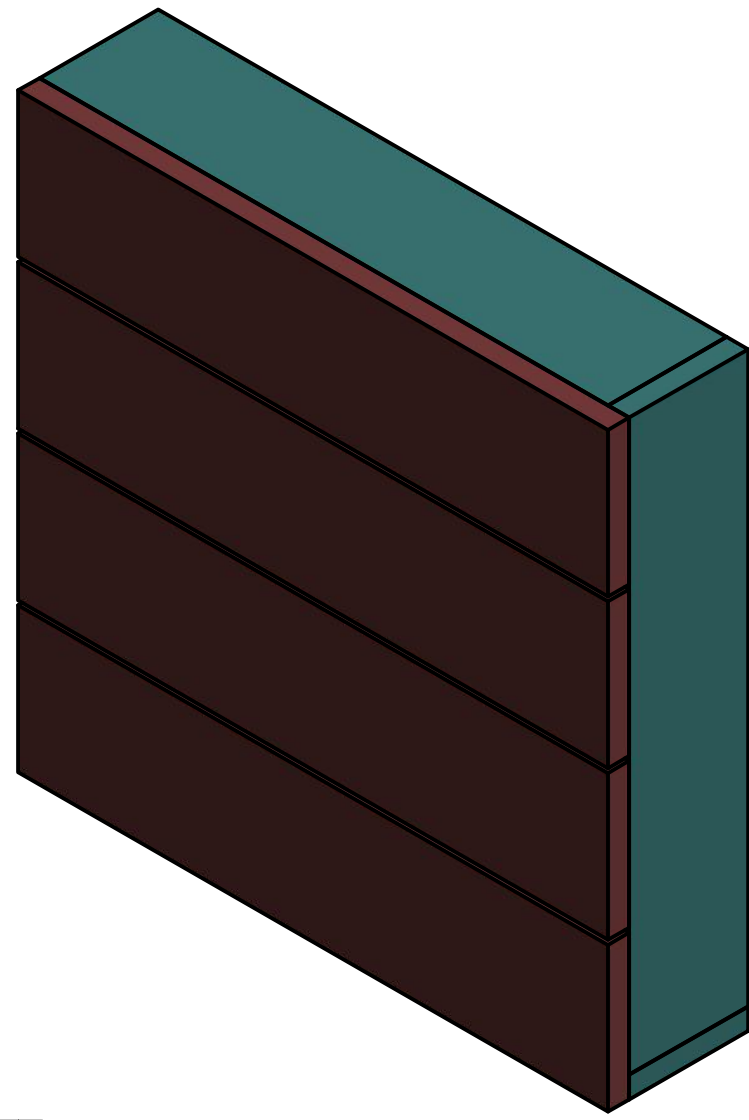

Bottom Platform

Top Frame

DRAWN	MI	1/15/2014	TITLE	
CHECKED			TITLE	
QA			TITLE	
MFG			TITLE	
APPROVED			TITLE	
			SIZE	DWG NO
			C	planter
			SCALE	REV
			SHEET	3 OF 4

4

3

2

1

D

D

3.500

4.250

4.500

3.500

2.000

16.750

17.375

16.625

19.250

19.875

C

C

B

B

A

A

45°

45°

DRAWN	MI	1/15/2014		
CHECKED			TITLE	
QA				
MFG				
APPROVED				
		SIZE	DWG NO	REV
		C	planter	
		SCALE	SHEET 4 OF 4	

4

3

4

2

1